

Electrochemical behaviour of modified activated carbons in aqueous and nonaqueous solutions

M. PAKUŁA

Naval Academy, 81-918 Gdynia, Poland

A. ŚWIĄTKOWSKI

Military Technical Academy 00-908 Warszawa, Poland

S. BINIAK*

Faculty of Chemistry, Nicolas Copernicus University, 87-100 Toruń, Poland

Received 27 September 1994; revised 17 February 1995

Cyclic voltammetric studies of electrodes prepared from unmodified and oxidized activated carbons were carried out. Three kinds of de-ashed commercial carbons were oxidized by treatment with concentrated nitric acid or by heating in air. For all samples the following properties were characterized: surface area (S_{BET}), quality and quantity of surface functionalities and total bonded oxygen. Cyclic voltammograms in aqueous and nonaqueous solutions (water, acetonitrile, water–acetonitrile mixtures) of electrolytes were recorded. Aqueous solutions with a wide pH range were used. The relations between cathodic peak potentials and pH values of the electrolyte solutions were estimated. An attempt to characterize the mechanisms of the electrode processes responsible for the formation of these peaks was undertaken.

1. Introduction

Cyclic voltammetric studies of the electrochemical behaviour of carbon materials in electrolyte solutions [1–20], have drawn attention to the close correlation between the shape of the cyclic curves and the chemical structure of the carbon electrode surface. In the literature, the peaks formed for definite values of potential peaks have been attributed to surface oxide species.

Unmodified materials, and in some cases, previously oxidized materials (electrochemically, oxygen rf-plasma, air and steam), such as carbon blacks [1, 2], graphite [3, 4], pyrolytic carbon [5], carbon fibre [6–12], activated carbon [13–15] and glassy carbon [16–19], were studied.

On the basis of these and other results, the assumption that quinone and hydroquinone groups are mainly responsible for the redox characteristics of carbon electrodes seems reasonable. It is also possible that other surface species are electrochemically active [2, 19], and that they are overlapped by significant capacitive currents.

The majority of electrochemical studies of carbon materials have been performed in only one kind of electrolyte (most often in aqueous solutions of inorganic salts or acids). An example of such studies, using electrochemically modified pyrographite electrodes, is the relation between the hydronium ion

concentration and the shape of the cyclic voltammograms (CVs) recorded in the aqueous solutions [4]. Some preliminary reports have analysed the CV peak potential against pH relation for different carbon electrodes [15, 16, 19].

In the presented study, the electrochemical behaviour of activated carbons with unmodified and chemically oxidized surfaces was analysed. Using different electrolytes, these investigations ought to enable the effect of the environment on surface electrode processes to be assessed.

2. Experimental details

2.1. Materials

The carbon materials and their modifications are presented in Table 1. The solvents were doubly distilled water and dried acetonitrile (pro analysi grade). The electrolytes (analytical grade) were LiClO_4 , Na_2SO_4 , H_2SO_4 , NaOH , and Britton–Robinson buffer, in concentrations of 0.05 or 0.1 M.

2.2. Instrumental

The electrochemical measurements were carried out using a typical setup (generator, potentiostat, X–Y recorder) and a three-electrode cell, shown diagrammatically in Fig. 1(a).

The working powdered activated carbon electrode (PACE) design is shown in Fig. 1(b). After prior

*Author to whom correspondence should be addressed

Table 1. Activated carbons tested

Notation	Source	Modification methods	Ref.
CWN2-NM	Commercial (ZEW, Racibórz, Poland)	De-ashed in conc. HF and HCl	[20]
CWN2-Ox	—	CWN2-NM oxidized in air at 673 K for 6 h (in fluid-bed process)	[20]
CWZ-NM	Commercial (HPSDD, Hajnówka, Poland)	De-ashed in conc. HF and HCl	[21]
CWZ-Ox	—	CWZ-NM oxidized in HNO ₃ at 353 K for 4 h and desorbed at 423 K	
RKD3-NM	Commercial (Norit, The Netherlands)	De-ashed in conc. HF and HCl	[22]
RKD3-Ox	—	RKD3-NM oxidized in HNO ₃ at 353 K for 5 h, heated in H ₂ at 448 K	[22]

vacuum desorption (10^{-2} Pa), the powdered carbon (grain size 0.075–0.067 mm, weight 20 mg) was placed in an electrode container and drenched with a deaerated solution to obtain a ~ 3 mm sedimentation layer. All potentials were measured, and are reported against a potassium chloride saturated calomel electrode (SCE) connected to the electrochemical cell via an agar-agar/KCl bridge. A platinum gauze served as counter electrode. After assembly, the

electrochemical cell was deaerated until the CV-curve shape was reproducible (24 h). The measurements were carried out in potential ranges preventing the electrochemical modification of the surface of the carbon materials tested.

Table 2 summarizes the estimated useful potential limits for oxidized carbon electrodes in aqueous solutions at three different pH (acidic, neutral and basic).

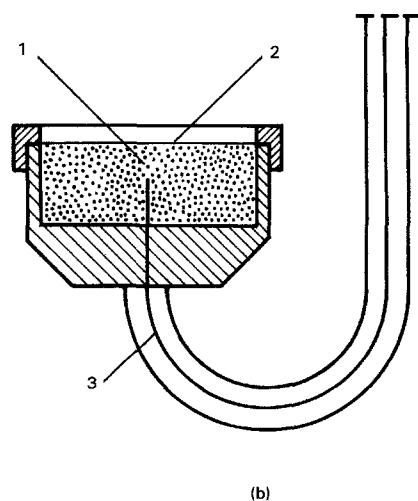
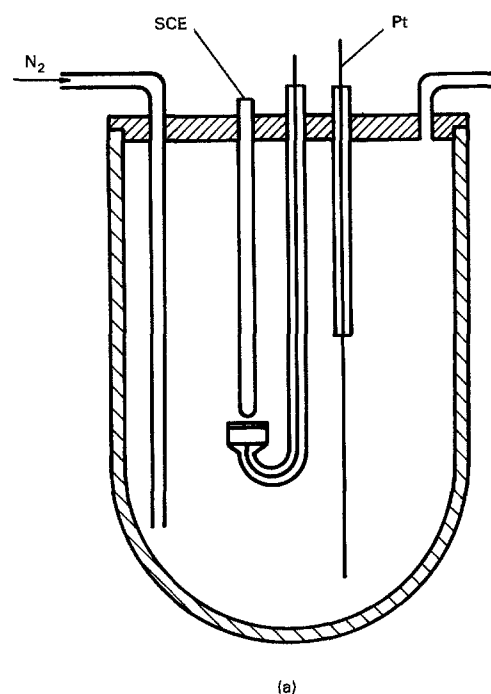

Fig. 1. Cross-section of the electrochemical cell (a) and the carbon electrode (b): (1) powdered activated carbon, (2) filter paper, (3) Pt contact.

2.3. Surface analysis

The specific surface areas (S_{BET}) of the studied carbons before and after modification were determined from the adsorption isotherms of benzene vapour at 293 K (20 °C) obtained using McBain–Baker sorption balances. The content of acidic functional groups was determined by neutralization with bases of various strengths [23], while the number of basic groups was estimated by neutralization with hydrochloric acid. The total amount of oxygen was determined by the method given in [24]. Additionally, the thermogravimetric investigation connected with the analysis of volatile products (mass spectrometric method) of thermal decomposition of the surface functional groups was carried out. Mass loss curves and mass spectra (CO₂ and CO) were recorded (Figs 2 and 3).

3. Results and discussion

The physical properties of activated carbon render it a difficult material to use as an electrode. Its extensive surface area leads to large double-layer charging currents which, tend to obscure faradaic current features. Studies of the redox-active surface oxide groups on the carbon materials require various properties of activated carbons to be well established.

Table 3 shows selected physicochemical properties of the electrode materials studied. The oxidation of carbon samples (CWZ and RKD3) by nitric acid caused a significant decrease ($\sim 30\%$) in specific surface area (S_{BET}). However, air (oxygen) treatment at 673 K (400 °C) leads to an increase in S_{BET} as a result of the additional activation of carbon (CWN2). Table 3 shows the number of functional groups obtained in relation to the units of mass or surface area of the carbons. It thus appears that in spite of similar quantities (mmol g^{-1}) of surface oxides (after modification), the carbons have different surface densities of functional groups (mmol m^{-2}). This

Table 2. Potentials of hydrogen and oxygen evolution for carbon electrodes in different electrolytes (*V* vs. SCE)

Electrolyte:	0.05 M H ₂ SO ₄		0.05 M Na ₂ SO ₄		0.1 M NaOH	
	H ₂	O ₂	H ₂	O ₂	H ₂	O ₂
Activated carbon						
CWN2-Ox	-0.42	+1.53	-0.94	+1.36	-1.08	+0.76
CWZ-Ox	-0.41	+1.48	-0.84	+1.22	-1.28	+0.68
RKD3-Ox	-0.46	+1.81	-1.08	+1.18	-1.26	+0.88

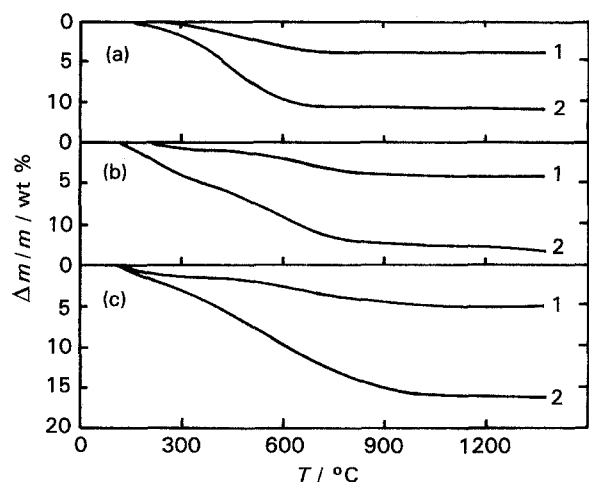
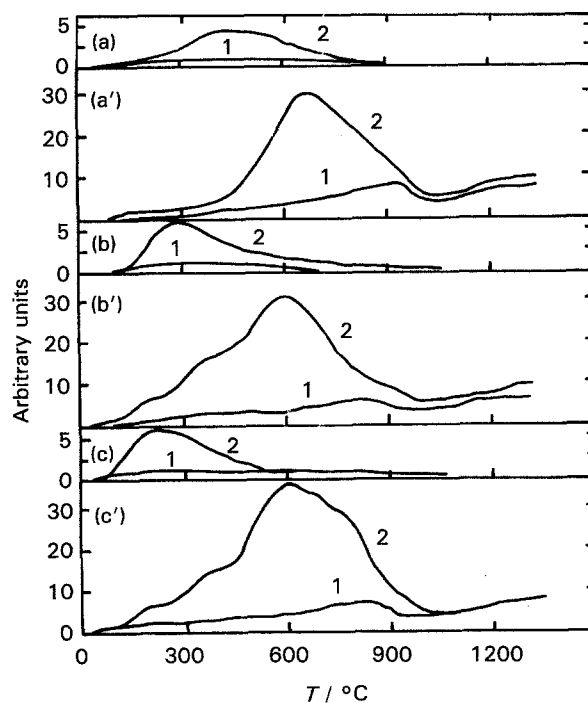

Fig. 2. Mass change derivative curves (TG) for the activated carbons: (a) CWN2, (b) CWZ, (c) RKD3; (1) unmodified carbons, (2) oxidized carbons.

last parameter should significantly influence the electrochemical behaviour of carbon electrodes.

To explain how surface oxidation and the nature of the solvent influence the electrochemical processes occurring at the solid/liquid interphase, the cyclic voltammograms for all the carbons studied were recorded in neutral aqueous, nonaqueous (acetonitrile) and mixed (1:1) solutions of 0.1 M LiClO₄. The cyclic curves obtained for CWN2 carbon are presented in Fig. 4 by way of example. For unoxidized (NM) carbons in aqueous solutions (Fig. 4(a)), no faradaic processes are observed in the potential ranges

Fig. 3. Mass spectra curves of CO₂ (a, b, c) and CO (a', b', c') emission for the carbons: (a, a') CWN2; (b, b') CWZ; (c, c') RKD3 (1: unmodified carbons, 2: oxidized carbons).

studied. The chemical or electrochemical oxidation of the carbon surface causes anodic and cathodic peaks to appear [1–20]. We also confirmed this effect in PACEs prepared from oxidized carbons (Fig. 4(b)). The voltammogram recorded for carbon electrode in

Table 3. Selected physicochemical properties of the activated carbon electrode materials studied

Activated carbon material	<i>S</i> _{BET} /m ² g ⁻¹	Number of functional groups /mmol g ⁻¹ (10 ⁴ mmol m ⁻²)				Total oxygen content /wt %
		total acidic	-OH	C=O	basic	
CWN2-NM	845	0.21 (2.48)	0.11 (1.3)	0.03 (0.35)	0.205 (2.42)	2.6
CWN2-Ox	1100	2.0 (18.18)	0.78 (7.09)	0.03 (0.27)	0.087 (0.79)	6.2
CWZ-NM	630	0.508 (8.06)	0.23 (3.65)	0.184 (2.92)	0.244 (3.87)	2.9
CWZ-Ox	455	2.113 (46.4)	0.71 (15.6)	0.105 (2.3)	0.019 (0.41)	9.7
RKD3-NM	970	0.786 (8.10)	0.113 (1.17)	0.19 (1.96)	0.249 (2.57)	2.5
RKD3-Ox	805	1.855 (23.0)	0.57 (7.08)	0.212 (2.63)	0.125 (1.55)	10.3

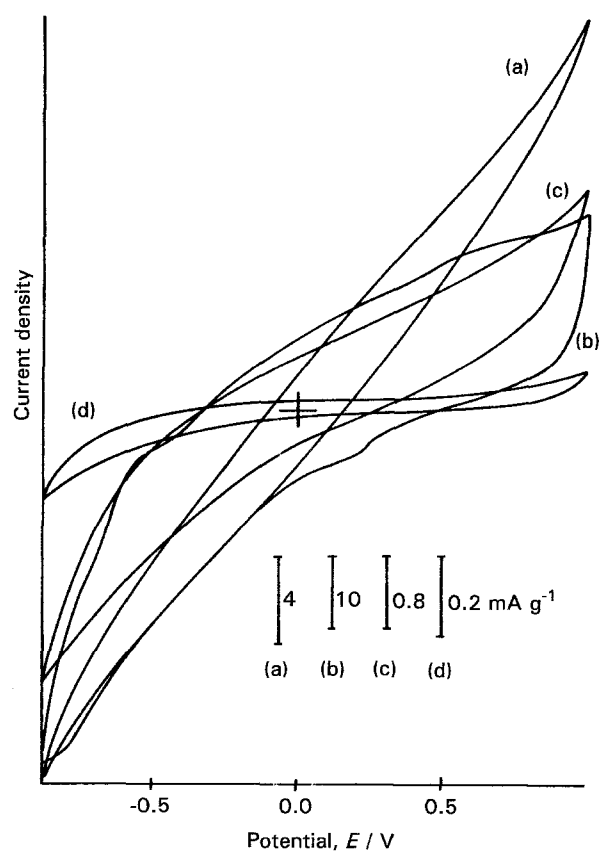

Fig. 4. Cyclic voltammograms of PACEs: (a) CWN2-NM in 0.1 M $\text{LiClO}_4/\text{H}_2\text{O}$, (b) CWN2-Ox in 0.1 M $\text{LiClO}_4/\text{H}_2\text{O}$, (c) CWN2-Ox in 0.1 M $\text{LiClO}_4/\text{H}_2\text{O} + \text{AN}$ (1:1), (d) CWN2-Ox in 0.1 M LiClO_4/AN . Sweep rate: 33.3 mV s^{-1} .

an aqueous organic solvent (Fig. 4(c)) shows the partial disappearance, and in a nonaqueous solvent, the complete disappearance (Fig. 4(d)) of the peaks on the cathodic and anodic waves. The charge transferred in the anodic and cathodic processes decreases when the polarity of the solvent and oxonium/hydroxyl ion concentration in the background aqueous solution does so. This indicates that protons participate in the surface electrochemical processes [14–16, 25–28], a fact confirmed by analysis of the changes in shape of the cyclic voltammograms for all the oxidized carbons studied, obtained with different sweep rates. Some of the results are presented in Fig. 5. On the basis of these results, we also estimated the sweep rate ($v = 5 \text{ mV s}^{-1}$), for which in aqueous environments we obtained the best-defined anodic and cathodic peaks for all the PACEs from oxidized carbons.

To define the possible mechanism of the surface electrochemical reactions, the cyclic voltammograms for oxidized carbons were recorded in aqueous blank electrolytes over a wide pH range. For CWN2-Ox and CWZ-Ox carbons, $\text{aq. H}_2\text{SO}_4$ – aq. NaOH of constant ionic strength were used. The RKD3-Ox carbon was studied in Britton–Robinson buffer. The cyclic voltammograms for extreme pH values (acidic and basic solutions) are shown in Fig. 6. In all the recorded curves there are well-defined and less well-defined cathodic and anodic peaks, the potentials of which are pH-dependent. For acidic solutions (Fig.

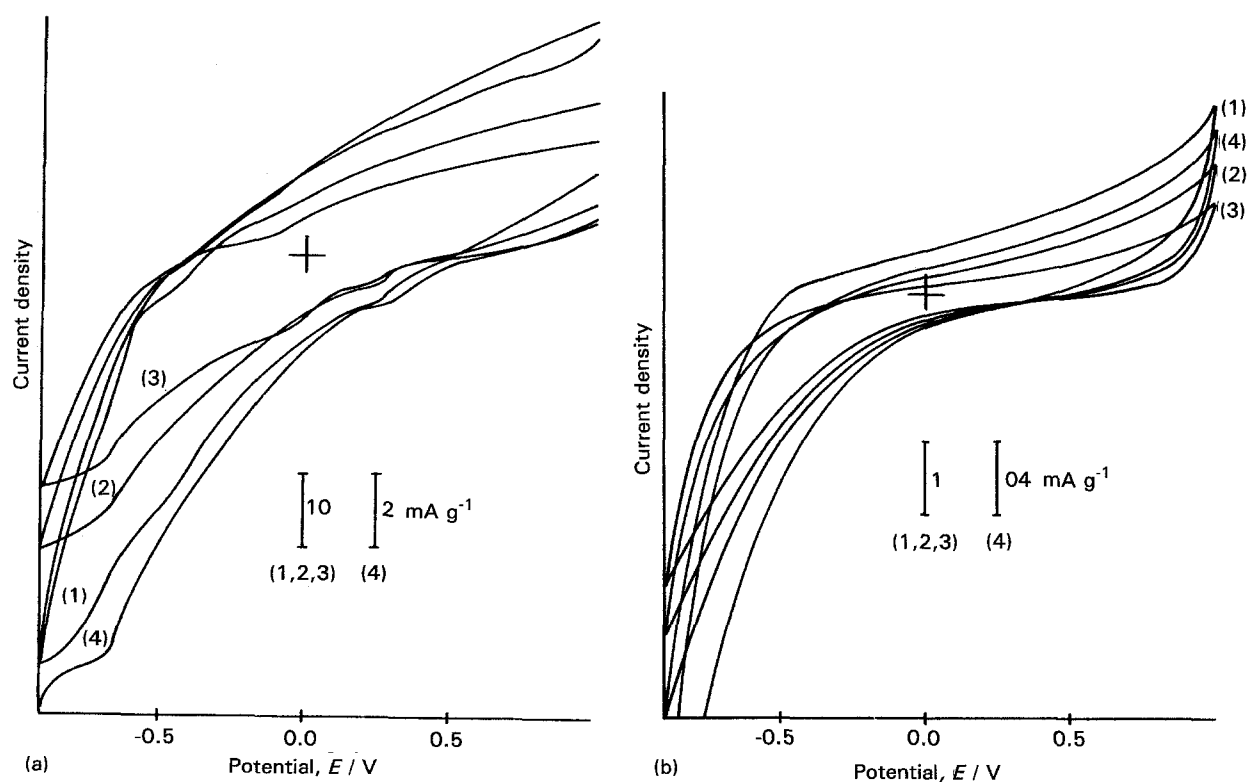

Fig. 5. Cyclic voltammograms of CWN2-Ox carbon recorded in aqueous 0.05 M Na_2SO_4 (a) and acetonyl/0.1 M LiClO_4 systems (b) for various sweep rates: (1) 50, (2) 20, (3) 10 and (4) 5 mV s^{-1} .

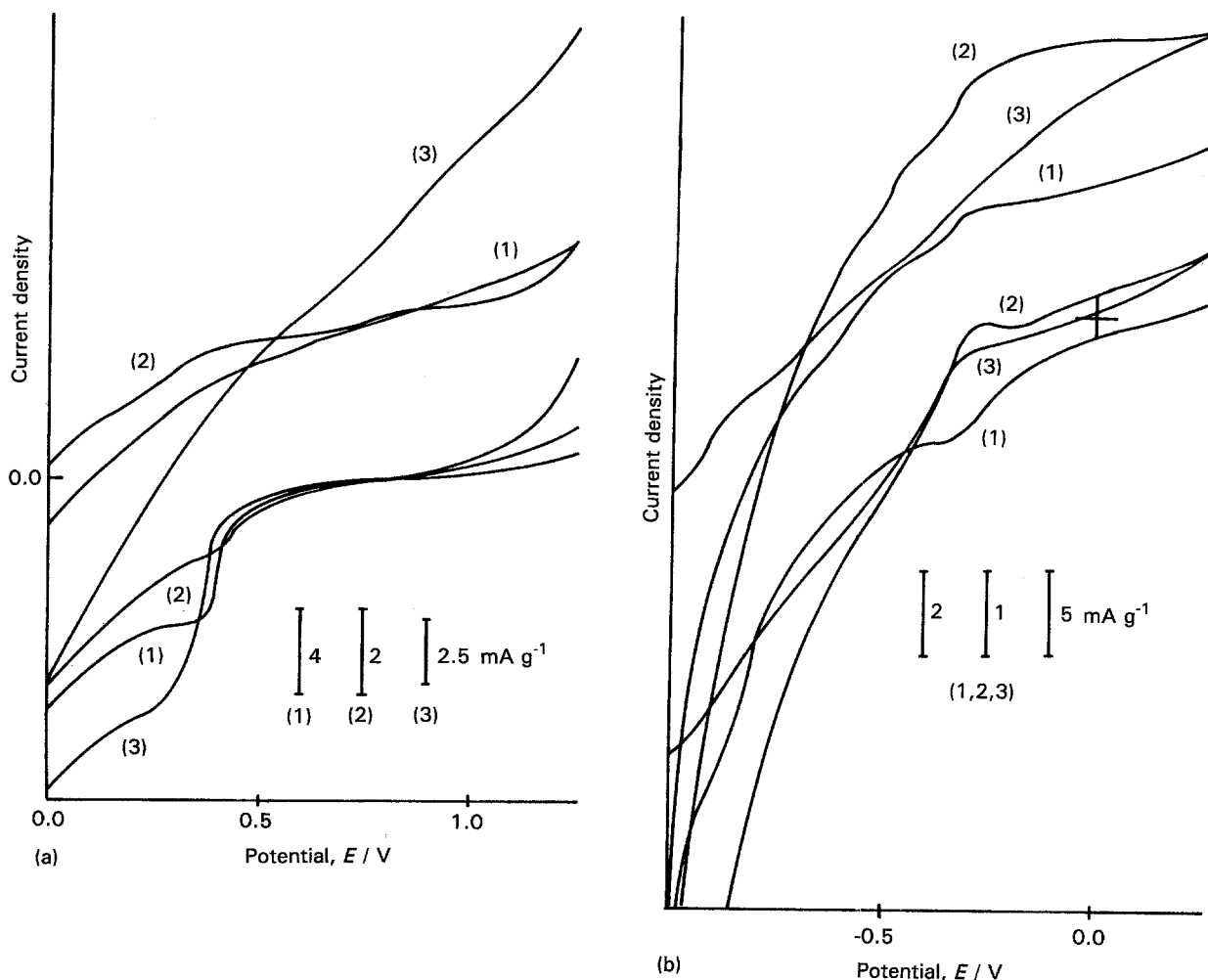

Fig. 6. CVs of carbons: (1) CWN2-Ox, (2) CWZ-Ox, (3) RKD3-Ox recorded in 0.05 M H_2SO_4 (a) and 0.1 M NaOH (b). Sweep rate: 5 mV s^{-1} .

6(a)), cathodic peaks (I) in the potential range (E_c^I) from 0.50 to 0.40 V (the poorest for CWZ-Ox carbon) were recorded. On the anodic sections of the CV curves, two broad, poorly-formed peaks (E_a^I and E_a^{II} in the potential ranges 0.35–0.45 V and 0.90–1.20 V, respectively) can be seen for all the oxidized carbons.

In a basic solution (Fig. 6(b)) the first cathodic peak potential shifts to more negative values (from -0.20 to -0.35 V) for all oxidized carbons. The second cathodic peak appears for CWN2-Ox and RKD3-Ox carbons in the potential range from -0.85 to -0.95 V and for CWZ-Ox carbon at $E_c^{II} - 0.55$ V. On the anodic waves there are two broad peaks (E_a^I : from -0.30 to 0.05 and E_a^{II} : from -0.85 to -0.75 V) for CWN2-Ox and RKD3-Ox, and a single broad one (from -0.10 to -0.20 V) for CWZ-Ox (all poorly formed).

In environments of medium pH, a relatively well-formed reduction peak (I) can be also seen. Its half-wave potential depends strictly on the pH of the blank electrolyte. Some sections of the cathodic waves (including the peak in question) recorded in solutions of different pH are presented in Fig. 7 (e.g., CWN2-Ox). It can be seen, in addition, that the height of the recorded reduction waves depend on pH, too. From these waves, the half-wave potentials can thus be estimated to within 5 mV.

To characterize the influence of the oxonium ion concentration on the redox reactions responsible for the observed peak, the relations between half-wave potentials and pH values are presented (Fig. 7). Earlier, these relations had been estimated for anodic and cathodic peaks obtained for activated glassy carbon electrodes [16, 17, 19] and over a limited pH

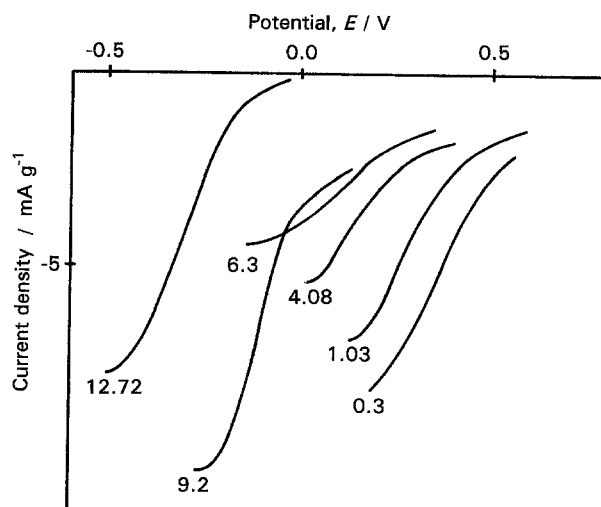
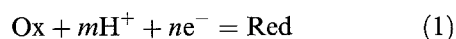

Fig. 7. Cathodic scans (sections) of CVs for CWN2-Ox recorded in aqueous electrolytes of different pH.

range for activated carbon paste electrodes [15]. In our studies we obtained the dependence of the half-wave potential for one selected cathodic peak (I) observed over the entire pH range used. This relationship is linear for all the PACEs studied (from previously oxidized carbons), and the slopes (calculated by the least squares method) take the values -51 ± 2 , -57 ± 3 , and -63 ± 2 mV/pH for CWN2-Ox, CWZ-Ox, and RKD3-Ox, respectively. Similar values (-62 and -64 mV/pH) were obtained for cathodic peaks obtained on cyclic voltammograms of glassy carbon electrode after oxygen rf-plasma treatment [16].

According to the general electrode reaction:



when $[\text{Ox}] = [\text{Red}]$, the Nernst equation predicts that the electrode potential for this process (E) is related to the formal electrode potential (E^0) by

$$E = E^0 - (m/n)(0.059 \text{ V}) \text{pH} \quad (2)$$

When $m = n$, a theoretical slope of -59 mV/pH for the $E = f(\text{pH})$ relationship is expected. The Nernst slopes obtained in our work are in good agreement with theoretical values when equal numbers of electrons and protons are transferred.

In particular, good agreement with theoretical values was obtained for carbons oxidized with concentrated nitric acid (CWZ-Ox, RKD3-Ox). We suggest, therefore, that this oxidizer yields surface functional groups with a chemical structure similar to those in the model system [25–28]. We would expect to find quinones of different types (e.g. 1,2- and 1,4-), as well as different local environments on the carbon surface. These could be expected to exhibit significant variations in their reduction potentials.

The presence of other cathodic and anodic peaks point to electrochemical activity on other oxygen

species existing on carbon surfaces (see Table 3). Additionally, they can be overlapped by significant capacity currents [29]. However, it should be remembered that the real chemical structure of an oxidized carbon surface [30] depends on the hydrolysis of lactone, ester or ether-like anhydrous systems and the ionization of some functionalities at extreme pH values (acidic or basic environments) [31]. These phenomena influence the surface density of species that can take part in charge-transfer processes, which explains the observed differences in height of reduction peaks in different environments (see Fig. 7).

These dependences can account for the redox processes described by the reactions, e.g. [18–21]:

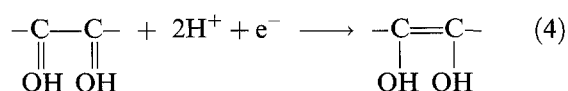

Comparison of the surface density (mmol m^{-2}) of the functional groups on activated carbons oxidized by nitric acid in relation to carbon oxidized in air shows a significantly higher (about 10 times) concentration of quinoid (carbonyl) structures. The gentler Nernst slope for CWN2-Ox points to the occurrence of reduction with partial ionization of the hydroxyl group, according to the reaction



This is probably due to the higher relative concentration of hydroxyl groups on this carbon (ca. 25 times) and the different distribution of their acidic strength. Another factor contributing to the discrepancy between the obtained and theoretical slopes could be the incomplete resolution of the overlapping peaks, which exhibit differing electrochemical reversibilities. The systems studied are unusually complicated, both chemically and electrochemically, so the mechanism

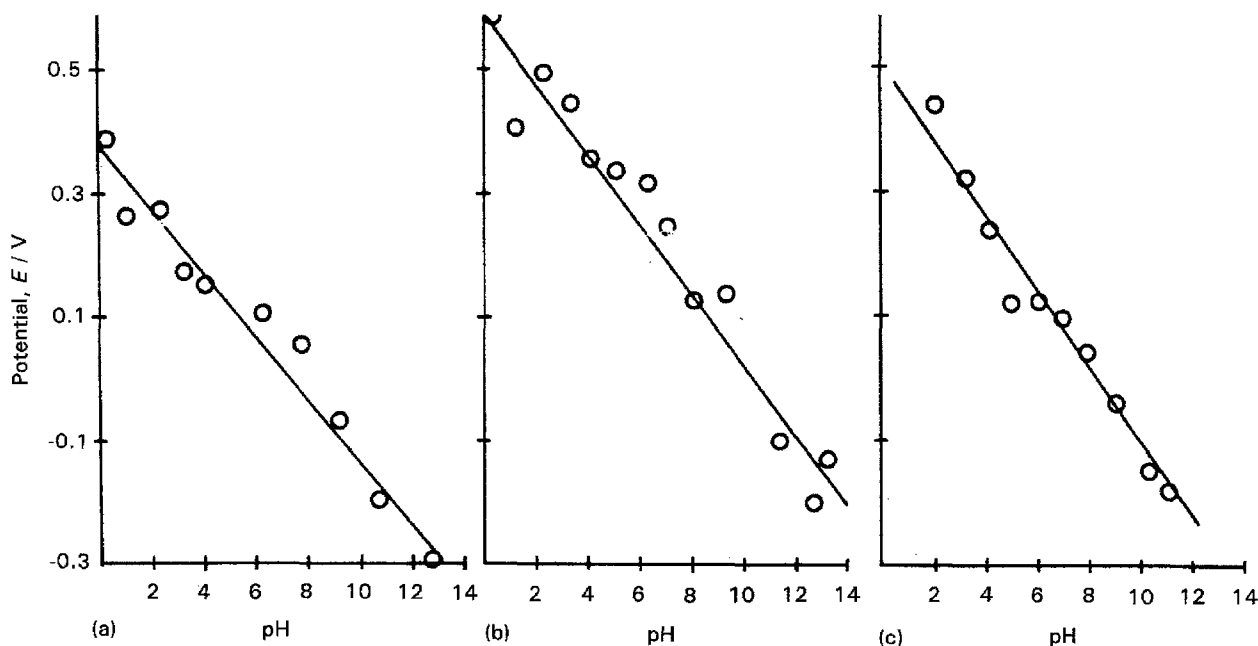

Fig. 8. Nernst plots of cathodic peak (I) potentials vs. pH for oxidized carbon electrodes: (a) CWN2-Ox, (b) CWZ-Ox, (c) RKD3-Ox.

of electrochemical activity and the role of surface species requires further experimental studies; this will be the subject of our next paper.

Acknowledgement

This work was partially supported by Polish Committee for Scientific Research, project 3 P405 001 05.

References

- [1] K. Kinoshita and J. A. S. Bett, *Carbon* **11** (1973) 403.
- [2] R. O. Loutfy, *Carbon* **24** (1987) 127.
- [3] K. F. Blurton, *Electrochim. Acta* **18** (1973) 869.
- [4] M. R. Tarasevich, E. D. Serezhenko, A. V. Dribinskij and S. V. Shulepov, *Elektrokhimija* **22** (1986) 180.
- [5] B. D. Epstein, E. Dalle-Molle and J. S. Mattson, *Carbon* **9** (1971) 609.
- [6] A. D. Jannakoudakis, P. D. Jannakoudakis, E. Theodoridou and J. O. Besenhard, *J. Appl. Electrochem.* **20** (1990) 619.
- [7] A. Proctor and P. M. A. Sherwood, *Carbon* **21** (1983) 53.
- [8] C. Kozłowski and P. M. A. Sherwood, *J. Chem. Soc., Faraday Trans. I* **80** (1984) 2099.
- [9] E. Theodoridou, A. D. Jannakoudakis, J. O. Besenhard and R. F. Sauter, *Synth. Met.* **14** (1986) 125.
- [10] S. Noffe, *Carbon* **25** (1987) 761.
- [11] M. R. Alexander and F. R. Jones, *Carbon* **32** (1994) 785.
- [12] S. Biniak, M. Pakuła and A. Świątkowski, *Monatsh. Chem.* **125** (1994) 1365.
- [13] D. R. Lowde, J. O. Williams, P. A. Attwood, R. J. Bird, B. D. Nicol and R. T. Short, *J. Chem. Soc., Faraday Trans. I* **77** (1979) 2312.
- [14] P. Zóttowski, *J. Power Sources* **1** (1976/77) 285.
- [15] J. D. Kaplan, J. H. March and S. W. Orchard, *Electroanalysis* **5** (1993) 509.
- [16] J. Schreurs, J. van der Berg, A. Wonders and E. Barendrecht, *Recl. Trav. Chim.* **103** (1984) 215.
- [17] J. H. Marsh and S. W. Orchard, *Carbon* **30** (1992) 895.
- [18] M. L. Bowers and B. A. Yanser, *Anal. Chim. Acta* **243** (1993) 43.
- [19] Y. Yung and Z.-G. Lin, *J. Electroanal. Chem.* **364** (1994) 23.
- [20] S. Biniak, M. Pakuła and A. Świątkowski, *Ext. Abstr. of ISE 36th Meeting*, Salamanca (1985), p. 2160.
- [21] S. Biniak, M. Pakuła, A. Świątkowski and S. Ziętek, *Przemysł chemiczny* **68** (1989) 468.
- [22] J. Kaźmierczak, S. Biniak, A. Świątkowski and K. H. Radeke, *J. Chem. Soc., Faraday Trans. I* **87** (1991) 3557.
- [23] H. P. Boehm, E. Diehl, W. Heck and R. Sappok, *Angew. Chem.* **76** (1964) 742.
- [24] W. Kopycki, D. Fraisse and J. Bińkowski, *Anal. Chem.* **25** (1980) 829.
- [25] I. Bailey and I. M. Ritchie, *Electrochim. Acta.* **30** (1985) 3.
- [26] M. R. Tarasevich, V. A. Bogdanovskaya and N. M. Zagudaeva, *J. Electroanal. Chem.* **223** (1987) 161.
- [27] S. A. Petrova, M. V. Kolodashny and O. S. Ksenschek, *Elektrokhimija* **25** (1989) 1493.
- [28] D. Golub, Y. Oren and A. Soffer, *J. Electroanal. Chem.* **227** (1987) 41.
- [29] B. Kastening, M. Hahn and J. Kremeskotter, *ibid.* **374** (1994) 159.
- [30] P. E. Fanning and M. A. Vannice, *Carbon* **31** (1993) 721.
- [31] J. Zawadzki in *Chem. Phys. Carbon* vol. 21 (edited by P. A. Throver), Marcel Dekker, New York (1988) pp 147–380.